

PHYSICS

IX

Part-2

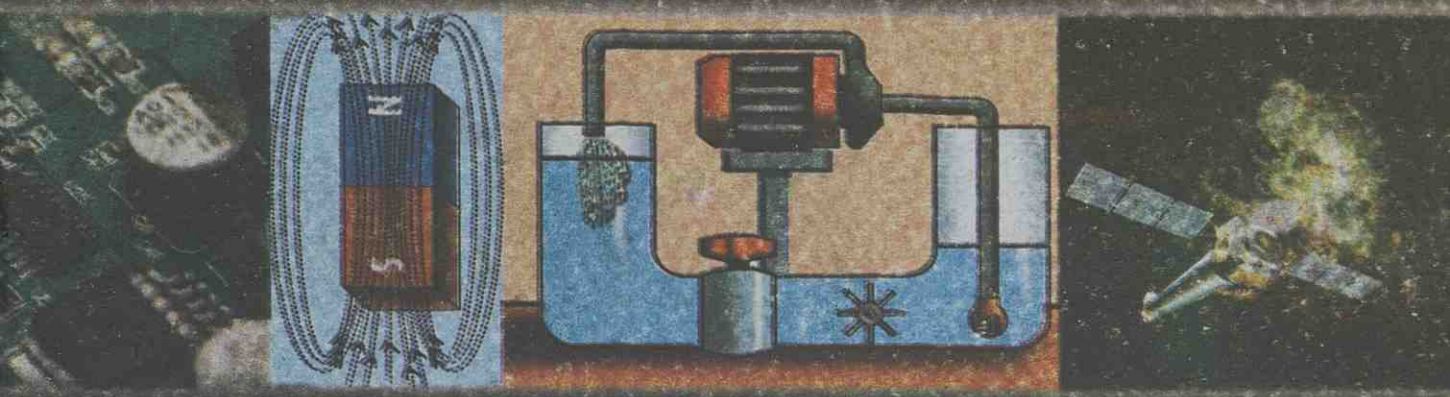

TB/IX/2016/530 (E)



Government of Kerala
Department of Education

CONSTITUTION OF INDIA

Part IV A

FUNDAMENTAL DUTIES OF CITIZENS

ARTICLE 51 A

Fundamental Duties- It shall be the duty of every citizen of India:

- (a) to abide by the Constitution and respect its ideals and institutions, the National Flag and the National Anthem;
- (b) to cherish and follow the noble ideals which inspired our national struggle for freedom;
- (c) to uphold and protect the sovereignty, unity and integrity of India;
- (d) to defend the country and render national service when called upon to do so;
- (e) to promote harmony and the spirit of common brotherhood amongst all the people of India transcending religious, linguistic and regional or sectional diversities; to renounce practices derogatory to the dignity of women;
- (f) to value and preserve the rich heritage of our composite culture;
- (g) to protect and improve the natural environment including forests, lakes, rivers, wild life and to have compassion for living creatures;
- (h) to develop the scientific temper, humanism and the spirit of inquiry and reform;
- (i) to safeguard public property and to abjure violence;
- (j) to strive towards excellence in all spheres of individual and collective activity so that the nation constantly rises to higher levels of endeavour and achievements;
- (k) who is a parent or guardian to provide opportunities for education to his child or, as the case may be, ward between age of six and fourteen years.

TB/IX/2016/530(E)

PHYSICS

Standard IX

Part-2



Government of Kerala
Department of Education

State Council of Educational Research and Training (SCERT) Kerala

2016

THE NATIONAL ANTHEM

Jana-gana-mana adhinayaka jaya he
Bharatha-bhagya-vidhata,
Punjab-Sindh-Gujarat-Maratha
Dravida-Utkala-Banga
Vindhya-Himachala-Yamuna-Ganga
Uchchala-Jaladhi-taranga
Tava subha name jage,
Tava subha asisa mage,
Gahe tava jaya gatha.
Jana-gana-mangala-dayaka jaya he
Bharatha-bhagya-vidhata,
Jaya he, jaya he, jaya he,
Jaya jaya jaya jaya he!

PLEDGE

India is my country. All Indians are my brothers and sisters.

I love my country, and I am proud of its rich and varied heritage. I shall always strive to be worthy of it.

I shall give my parents, teachers and all elders respect, and treat everyone with courtesy.

To my country and my people, I pledge my devotion. In their well-being and prosperity alone lies my happiness.

State Council of Educational Research and Training (SCERT)

Poojappura, Thiruvananthapuram 695012, Kerala

Website : www.scertkerala.gov.in, e-mail : scertkerala@gmail.com

Phone : 0471 - 2341883, Fax : 0471 - 2341869

Typesetting and Layout : SCERT

Printed at : KBPS, Kakkannad, Kochi-30

© Department of Education, Government of Kerala

Dear students,

You were provided with opportunities to observe your surroundings and engage in simple experiments and investigative activities in earlier classes. The classroom experience, undoubtedly, might have helped you to record the information systematically and assimilate ideas through discussion and analysis. While understanding the scientific approach, there should also be the attitude to take forward the skills to apply them in day-to-day life. Moreover, an eco-friendly perspective must be adopted too. All these, through direct experiences, enquiry and understanding preferably.

This textbook presents ideas in accordance with this. There are experiments, illustrations and explanatory details that enable the comprehension of these ideas. There are opportunities appropriate to the situation to make learning more enjoyable.

Go ahead, thinking, asking questions, approaching ideas critically and quizzing with teachers and friends. Make learning a joyful experience.

Regards,

Dr. P. A. Fathima

Director, SCERT

Textbook Development Team

Members

- Unnikrishnan T.I.**
Headmaster (Rtd.), AKKRHS for Boys,
Kozhikode
- Pradeepkumar K.V.**
HSA, Moothedathu HSS, Thaliparamba,
Kannur
- Sureshkumar K.**
HSA, AMHSS, Thirumala,
Thiruvananthapuram
- N.V. Surendran**
HSA, GHSS, Chundangapoyil, Kannur
- Hassan C.C.**
Headmaster, MMVHSS, Parappil, Kozhikode
- Preethi K.A.**
HSA, Sabari Highschool, Pallikurup,
Palakkad
- P.D. Baby**
Headmaster, St. Antony's HSS, Mutholy,
Pala
- Gopalan N.K.**
HSA (Rtd.), KKMGVHSS, Orkatteri

English Version

- D. Thomas**
Professor (Rtd.), Department of English,
Mar Ivanious College, Thiruvananthapuram
- N.G. Krishnapillai**
Professor (Rtd.), Department of Physics,
VTM NSS College, Dhanuvachapuram
- M. Divakaran Nair**
Professor (Rtd.), Department of Physics,
MG College, Thiruvananthapuram
- Dr. M. Lalitha**
Librarian (Rtd.), SCERT, Kerala
- Dr. Nizamudeen.K.M**
Asst. Professor (Physics),
Kannur University

Artists

- Mooza Mustajib E.C.**
MMETHSS, Melmuri, Malappuram
- Lohithakshan K.**
Assisi HSS for deaf,
Malaparambu, Malappuram

Academic Coordinator

- Dr Ancy Varughese**
Research Officer, SCERT, Kerala

Contents

- 6. Current Electricity 119
- 7. Magnetic Effect of Electric Current .. 139
- 8. Our Universe 149

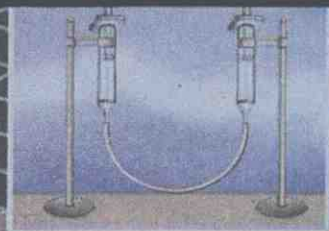
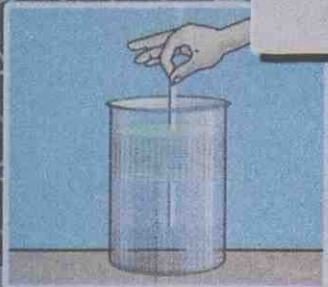

Certain icons are used in this
textbook for convenience



*For further reading
(Evaluation not required)*



*ICT possibilities for making
concepts clear*



Significant learning outcomes



Let us assess



Extended activities

Current Electricity



Both the circuits use the same type of bulbs. Yet there is a difference in the intensity of light. What could be the reason?

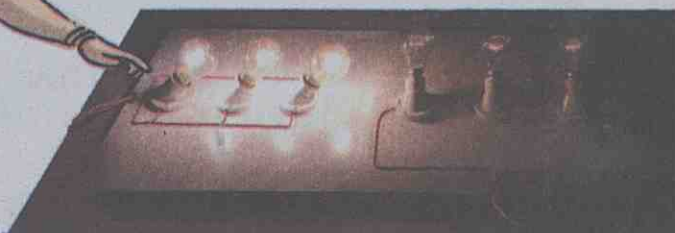

This doubt was raised by a child when she was observing an experiment at a science fair.

Why is there a difference in the intensity of light from the bulbs in the two circuits?

Let's examine.

We have learnt that objects can be charged by rubbing and these can be used for charging other objects.

Observe Fig. 6.1(a).

A positively charged electroscope is connected to the earth through a switch using a conductor.

- What kind of charge is present in this electroscope?
Flowing/ Static
- What happens to this charge when the switch is turned on?
- Will the flow of charge sustain in this arrangement?

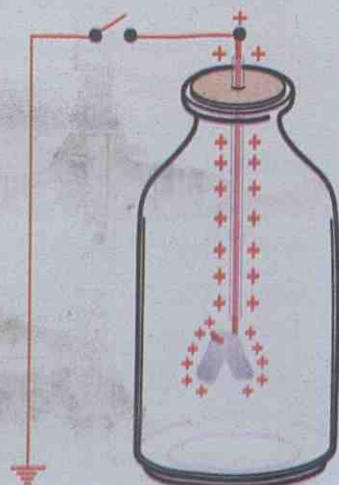

Fig. 6.1 (a)

Observe Fig. 6.1(b).

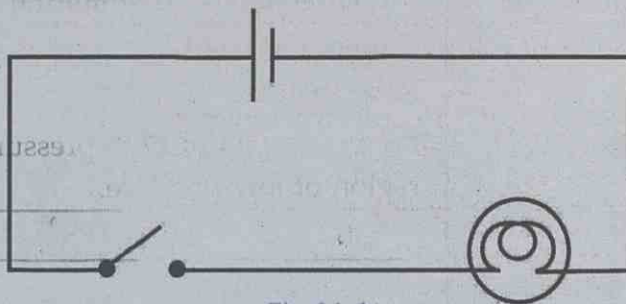

Fig. 6.1 (b)

A circuit with a cell, a bulb and a switch is given in Fig. 6.1 (b).

- Will the flow of electric current sustain in the circuit if it is switched on?

What difference is there in the flow of current in Fig. 6.1 (a) and Fig. 6.1(b)?

In the first circuit, there is a flow of charge for a short interval of time and there is a continuous flow of charge in the second.

The motion of charges creates current. Current is formed in conductors by the flow of free electrons in it and by the flow of ions in gases and electrolytes.

How does the electric charge flow? Let's see.

Observe Fig 6.2.



Coulomb

The unit of electric charge is coulomb. If the repulsive force between two identically charged pointed objects kept at a distance 1 m is 9×10^9 N, then the charge in each of them is 1 coulomb. This is equal to the charge of 6.25×10^{18} electrons. A force of 9×10^9 N is equivalent to the force exerted by the earth on an object of mass 10^4 kg kept on the surface of the earth. If 10^4 kg is approximately the mass of one elephant, 10^9 kg mass is approximately equal to the mass of one lakh elephants.



Fig. 6.2

Complete the table based on different situations as shown in Fig 6.2.

Situation	Direction of flow/motion
Ball falling down	Downwards from a higher level to a lower level.
Flow of air	From a region of high pressure to a region of low pressure.
Flow of water	
Flow of heat	

Table 6.1

You might have understood now that there should be a difference in energy levels between two points if any type of flow is to occur.

Observe Figs. 6.3(a) and (b).

- If the valve is opened, in which one will there be a flow of water and rotation of the wheel?

- Why?

In Fig. 6.3(a) isn't the water level, or potential energy at A, greater than that at B? It is due to the difference in the energy level or the gravitational potential difference that there is a flow of water and consequent rotation of the wheel.

Observe Fig. 6.4.

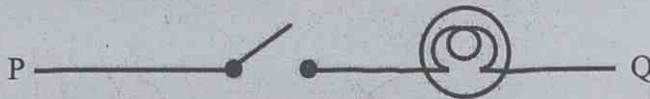

Fig. 6.4

A bulb is connected to a switch, using a conductor.

- Will the bulb glow if switched on? Why?

There is no potential difference between P and Q. Hence there is no flow of current and the bulb does not glow.

For a bulb to glow in a circuit, as shown in Fig. 6.4, a potential difference should be maintained between P and Q.

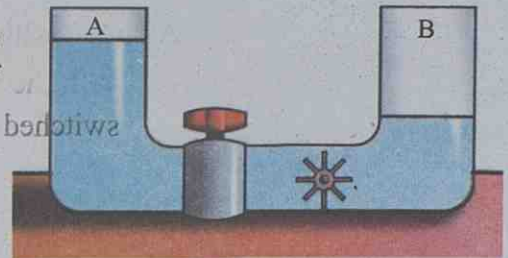

Fig. 6.3 (a)

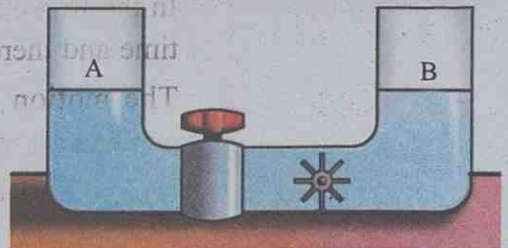

Fig. 6.3 (b)

Potential and potential difference

There should be a potential difference between two points of a conductor, if there is to be a flow of current between them. Current flows from a point of high electric potential to a point of low electric potential.

The unit of potential difference is volt (V). Voltmeter is the device to measure this.

If 1 joule of work is done to move one coulomb charge from one point to another, then the potential difference between the points is 1 volt.



Electromotive force

Electromotive force (emf) is the ability to maintain the potential difference between the ends of a conductor. The emf of a source of current is the potential difference between its ends when the source is in an open circuit. The emf of a cell is measured in the unit volt.

Observe Fig. 6.5.

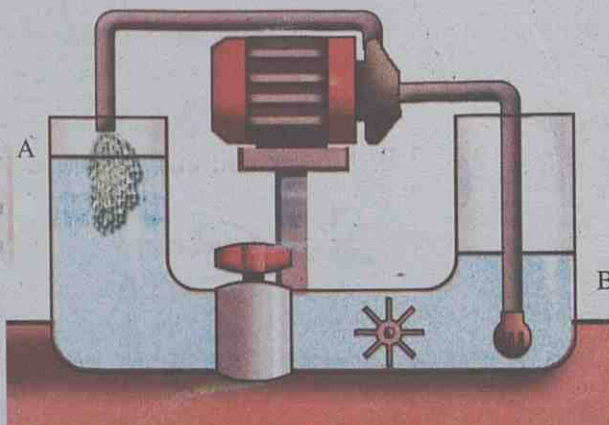

Fig. 6.5

The pump has been used in such a way that the same quantity of water that flows from A to B per second is returned to A from B in the same period of time.

- Why is there a continuous flow of water when the valve is opened?

Here, is it not due to the working of the pump, which is an external source of power, that the potential difference was maintained and the flow of water was made possible continuously?

If the bulb shown in Fig. 6.4 is to glow continuously, shouldn't there be an external source? Such sources are the sources of emf. Write down some sources of emf familiar to you.

- Generator

Write down the energy change in each.

- Generator : mechanical energy → electrical energy
- Cell

Compare Fig 6.5 and Fig 6.1(b) and complete the table.

Water circuit	Pump	Water wheel	Valve
Electric circuit	Cell	Flow of electric charge

Table. 6.2



Voltmeter



Voltmeter is the device used to measure the potential difference and emf. It should be included in a circuit with its positive terminal to the positive of the cell and the negative terminal to the negative of the cell. The voltmeter should be connected across the points where the potential difference is to be measured.

Haven't you learnt that a source of emf is essential to maintain a potential difference between the ends of a conductor and to maintain the flow of current through the conductor?

Make the circuit given in Fig. 6.6 using a voltmeter, a 12 V, 3 W bulb, a cell and a switch. Operate it.

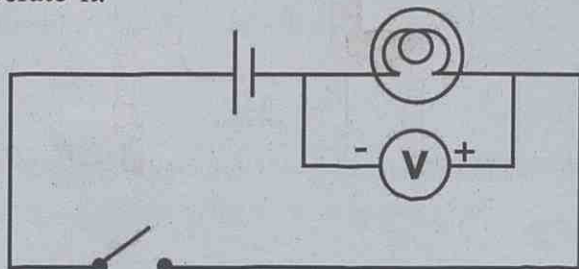

Fig. 6.6

- How should you connect a voltmeter in a circuit?

- Connect 1.5 V, 6 V and 9 V batteries and find out the voltage available to the bulb in each case and record it in the table.

Cell used/ Battery	Voltage the bulb gets
1.5 V	
6 V	
9 V	

Table 6.3

Different types of batteries were used to increase the voltage. Let's examine how this can be done by connecting cells.

- In what mode are the cells connected within the remote control of a TV?

- If 4 cells of 1.5 V each are connected in series, what is the total voltage?

Combination of cells

A battery is a combination of two or more cells connected in a suitable manner. Cells can be connected in two ways.

1. Series connection

The method of connecting cells one after the other in such a way that the positive of one cell is connected to the negative of another cell.

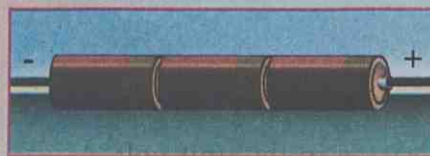

Salient features

- The total emf is the sum of the emf of all the cells.
- The current passing through each cell is the same.
- The internal resistance developed in the circuit by the battery increases.
- The current in the external circuit increases under high voltage.

2. Parallel connection

The method of connecting similar poles together.

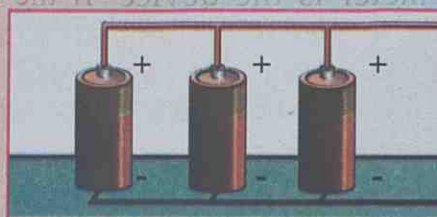

Salient features

- If all the cells have equal emf then the emf of the circuit is the same as that of a single cell.
- The total current flowing in the circuit splits up and flows through each cell.
- The internal resistance of the circuit is very low.
- More current can be made available for a longer time under low voltage.

- How can you connect four cells of 1.5 V each to get 3 V? What is the advantage of doing so? Draw the circuit.

 What is the need to use sources of emf in circuits?

Electric current

Electric current is the flow of electric charges. If 10 coulomb charge flows in a circuit in 5 s, how much is the charge flowing in the circuit in one second?

$$\text{Charge, } Q = 10 \text{ C}$$

$$\text{Time, } t = 5 \text{ s.}$$

$$\text{Charge flowing in one second} = \frac{10}{5}$$

$$= 2 \frac{\text{C}}{\text{s}}$$

Current is the quantity of charge that flows through a conductor in a circuit in one second.

If a charge of Q coulomb flows in a time t second, then how much is the quantity of charge that flows in one second?

$$\text{Current (I)} = \frac{\text{Quantity of charge}}{\text{Time taken}}$$

$$\text{That is I} = \frac{Q}{t}$$

$$\text{Unit of current} = \frac{\text{Unit of charge}}{\text{Unit of time}}$$

What is the unit of current?

Let's measure the current in a circuit.

Draw a diagram of the circuit containing an ammeter, switch, cell and a bulb connected in series. Compare the diagram you have drawn with the circuit diagram given below and make the circuit accordingly.

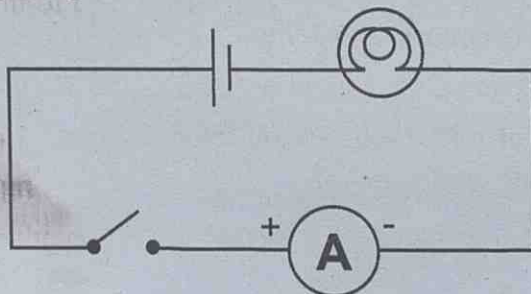

Fig. 6.7

Repeat the experiment by increasing the number of cells in series. Record the ammeter reading in each situation and analyse.

Number of cells	Ammeter reading
1	
2	
3	

Table 6.4

- What change occurred in the ammeter reading when the number of cells was increased?

- What about the intensity of light from the bulb?

- How are the current and the intensity of light related to each other?

Ammeter reading indicates the current flowing through the bulb. The intensity of light from the bulb increases with the increase in the current.

- What is the current in a conductor if 2 C charge flows in 10 s?

Haven't you learnt that there must be a potential difference between the ends of a conductor if current should flow through it? If so, is there any relation between current and potential difference?

Ohm's law

Let's try an activity.

Draw a circuit diagram by including a nichrome wire (30 cm), cell, switch, ammeter and voltmeter. Compare the circuit you have drawn with the one given in Fig. 6.8. Ensure accuracy and complete the circuit.

Measure current (I) and potential difference (V) and record them in the table.

Repeat the activity by increasing the number of cells in series.

Ammeter



Ammeter is the device used to measure the current in a circuit. The positive terminal of it must be connected directly to the positive of the cell and negative terminal, to the negative of the cell. Ammeter should be connected in series in the circuit. The needle of the device moves in accordance with the current in the circuit. We can measure the current by checking the position of the needle.

Unit of current is ampere (A). It is 1 C/s.

Milli ampere (mA) and micro ampere (μA) are smaller units.



See the section Ohm's Law in PhET in the IT @ School Edubuntu.



Flow of current through a conductor

In any conductor, there are positively charged ions at rest and free electrons. These free electrons are in random motion. When a conductor is connected to a source of emf, the free electrons start moving uniformly from the negative terminal to the positive terminal. But the free flow is hindered by the positive ions. As a result, the increased speed is reduced. Still the push from one terminal is experienced at the other end simultaneously. Hence the electrons that come out from the other end of the conductor are not the ones that have entered it. The same number of electrons entering a conductor returns to the source at the same time. These electrons drift with a slow speed (0.01 m/s) named drift velocity. Because of this drifting electric signals are transferred at the speed of light in the circuit. Remember that the speed at which a person walks alongside a current carrying conductor is 100 times that of the speed of these electrons!

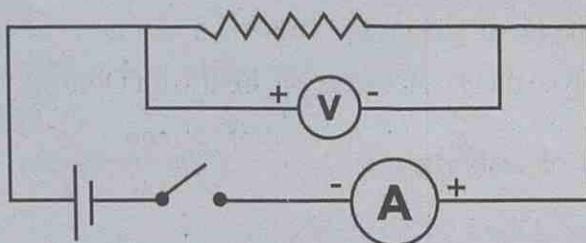

Fig. 6.8

Analyse the table and record the findings.

Sl.No.	Number of cells	V volt	I ampere	$\frac{V}{I}$
1	1			
2	2			
3	3			

Table 6.5

- What change occurred in the current when there was a change in voltage?
- Do you see any peculiarity in the value of $\frac{V}{I}$?

Current increases with increase in voltage.

$$V \propto I$$

$$V = \text{a constant} \times I$$

$$\frac{V}{I} = \text{a constant}$$

This constant is the resistance of the conductor. This is indicated by the letter R.

$$\therefore R = \frac{V}{I}$$

When temperature remains constant, the current through a conductor is directly proportional to the potential difference between its ends. In other words the ratio of potential difference to the current is a constant.

This was formulated by George Simon Ohm, a scientist. Hence this is known as Ohm's Law.

Resistors are conductors used to include a particular resistance in a circuit. Its symbol is $\text{---}\text{---}\text{---}$

- On the basis of the information gathered from Table 6.5, draw a V – I graph. Mark I in the X axis and V in the Y axis.

- Is the graph a straight line?
- Analyse the graph and compare it with Ohm's Law.

$$\text{Unit of resistance} = \frac{\text{Unit of voltage}}{\text{Unit of current}}$$

$$= \frac{\text{Volt}}{\text{Ampere}}$$

$\frac{\text{Volt}}{\text{Ampere}}$ is ohm. The symbol of this is Ω (Greek letter omega). $1 \Omega = \frac{1\text{V}}{1\text{A}}$. From this what do you mean by 1 ohm?

If the potential difference between the ends of a conductor is 1 V when a current of 1 A flows through it, then the resistance of the conductor is 1 Ω .

If a conductor connected to one volt potential difference passes a current 1 A, then the conductor will have 1 Ω resistance.

Using the given figure, frame equations representing Ohm's Law.

- $R = \frac{V}{I}$
- $I = \dots\dots$
- $V = \dots\dots$

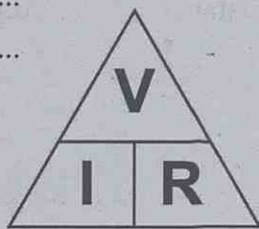

Fig. 6.9

Complete the following table based on Ohm's law.

Voltage (volt V)	Current (I) (ampere A)	Resistance (R) (ohm Ω)
12	4
.....	2	3
6	3

Table 6.6



George Simon Ohm
(1789 - 1854)



George Simon Ohm is a well-known German physicist. He was appointed Professor of Mathematics in the Erlangen University and later as Professor of Physics in Munich University.

It was he who found out the relation between potential difference, current and resistance. This is known as Ohm's Law. The unit of resistance is named after him.



Digital multimeter



This device is used to measure DC voltage, current, AC voltage and current, resistance of a conductor etc.

- **Function and range switch:** adjusts the function to be measured and its range
- **Display:** Displays the value digitally and directly
- **Common jack:** Negative test lead (*black*)
- **Plug in Conductor:** Positive test lead (*red*)
- **Plug in jack:** for 10 A current (*red*)
- **Jacks :** Connect properly, turn the switch to the required function and then by touching the ends of the jack, the reading can be understood.

Resistors

Arrange a circuit as shown in the figure.

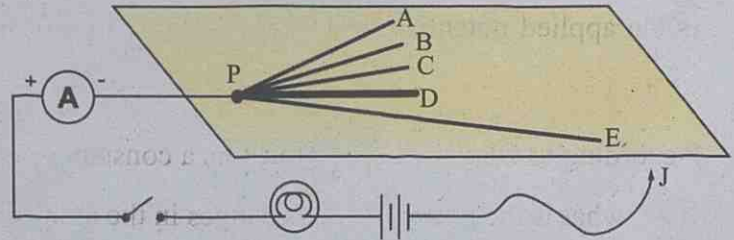

Fig. 6.10

Among the conductors fixed on the wooden plank, PA is iron, PB is aluminium, PC, PD and PE are nichrome. Their lengths are the same. PE has double the length. The thickness of PD is double that of the others. Touch the free end J at A,B,C,D and E and record in the table the ammeter reading at each instance.

Serial number	Resistor in the circuit	Ammeter reading (A)
1	Iron (PA)	
2	Aluminium (PB)	
3	Nichrome (PC)	
4	Nichrome (PD)	
5	Nichrome (PE)	

Table 6.7

Complete the worksheet based on the information derived from the table.

- Is the intensity of light from the bulb the same in each situation?

- Is the ammeter reading the same when different conductors of the same length and thickness were included?

- What change has occurred in the ammeter reading when the area of cross section of the same conductor is altered?

- Is there a change in the ammeter reading when the length of the same conductor is altered? Record.

- Is the applied potential difference the same in all cases?

- According to Ohm's Law, $\frac{V}{I}$ must be a constant (resistance, R).

If so, what is the reason for the changes in the ammeter readings?

Connect a 6 V bulb to a 6 V source.

Using a multimeter, measure the resistance of the bulb when the circuit is switched off. Switch on the bulb for a short time, then switch it off and immediately measure its resistance.

- Is the resistance the same in both the situations?
- When the circuit was switched on, was the temperature of the bulb low or high?
- Did the resistance increase or decrease when the temperature was increased?

List the factors affecting the resistance of a conductor, based on the worksheet.

- Area of cross section
- Nature of the material
-

The resistance of metals increases with the increase in temperature. Let's examine the role of a resistor in controlling the current in a circuit.

In the activity conducted above, touch the free end J at E and slowly slide it from E to P. Based on the observations, write down the answers.

- What change occurred in the intensity of light from the bulb?

- What may be the reason behind the change?

If the potential difference is constant, then the current is inversely proportional to the resistance. For a conductor of uniform area of cross section, the length of the conductor and the resistance are directly proportional.

Rheostat is a device designed on the basis of this principle.
Let's see what the use of a rheostat is.

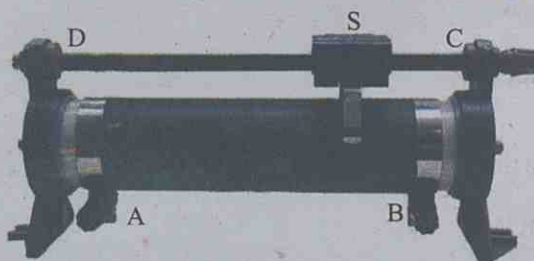



Fig. 6.11

In the figure, AB is a resistor wound over an insulator. The resistance of a circuit can be continuously changed by the sliding contact S. The change in the resistance regulates the current. The symbol of a rheostat is .

Make a circuit having a bulb, a cell, ammeter, rheostat and a switch in series. Switch on the circuit and adjust the sliding contact slowly. Observe the change in the brightness of the bulb.

Rheostat is a device used to regulate the current in a circuit by changing the resistance.

Given below is a table related to the resistance of a conductor. Complete the table suitably.

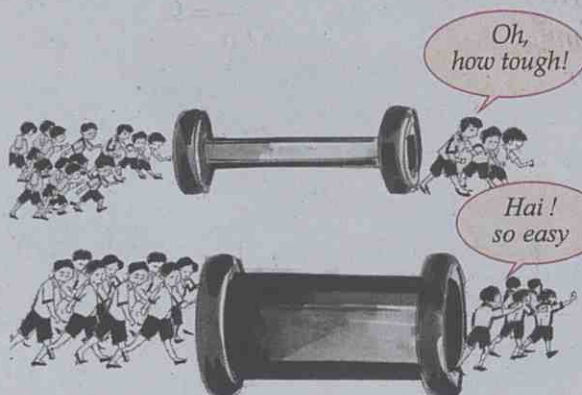

Length (l) (m)	Area of cross section (A) (m^2)	Resistance (R) Ω
1	1	R
2	1	$2R$
1	2	$\frac{1}{2}R$
2	2
1	$\frac{1}{2}$

Table 6.8

Analyse the completed table and write down the inferences.

The resistance of a conductor increases with the increase in the length of the conductor and decreases with increase in the area of cross section.

$$R \propto l \text{ and } R \propto \frac{1}{A}$$

$$\text{That is } R \propto \frac{l}{A}$$

$$R = \text{a constant} \times \frac{l}{A}$$

$$R = \rho \frac{l}{A} \text{ (the constant is indicated by the Greek letter } \rho \text{ (rho)).}$$

$$\text{If so } \rho = \frac{RA}{l}$$

ρ is the resistivity of the material the conductor is made of. The length of a conductor of resistance $R \Omega$ is 1 m and its area of cross section is 1 m^2 . Calculate the resistivity of the material the conductor is made of.

$$\text{Length, } l = 1 \text{ m}$$

$$\text{Area of cross section, } A = 1 \text{ m}^2$$

$$\text{Resistivity } \rho = \frac{RA}{l} = \frac{R \times 1}{1}$$

$$\rho = R$$

In this mathematical problem you have learnt that $\rho = R$. Can you formulate a definition for resistivity?

Resistivity of a substance is the resistance of the conductor of unit length and unit area of cross section. The resistivity of a substance is a constant at fixed temperature. But it will be different for different materials.

Unit of resistivity =

$$\frac{\text{Unit of resistance} \times \text{Unit of area of cross section}}{\text{Unit of length}}$$

$$\text{Unit of length}$$

$$= \frac{\Omega \times \text{m}^2}{\text{m}} = \Omega \text{ m}$$

The unit of resistivity is $\Omega \text{ m}$.

Arrangement of resistors

Two different circuits which can be constructed using a 6 V battery, 3 W, 6 V bulb and a switch are given (Fig 6.12). Construct these circuits and operate it. Write down the answers based on your observations.



Conductivity

The conductivity of a conductor is the reciprocal of its resistivity. This is denoted by the symbol σ (from the Greek letter sigma).

$$\sigma = \frac{1}{\rho}$$

Unit of conductivity =

$$\frac{1}{\text{Unit of resistivity}}$$

$$= \frac{1}{\Omega \text{ m}} = \Omega^{-1} \text{ m}^{-1}$$

Power and resistance

The filament of any bulb will have a fixed resistance. They work under the same potential difference. Bulbs of the same power will have the same resistance.

$$R = \frac{V^2}{P}$$

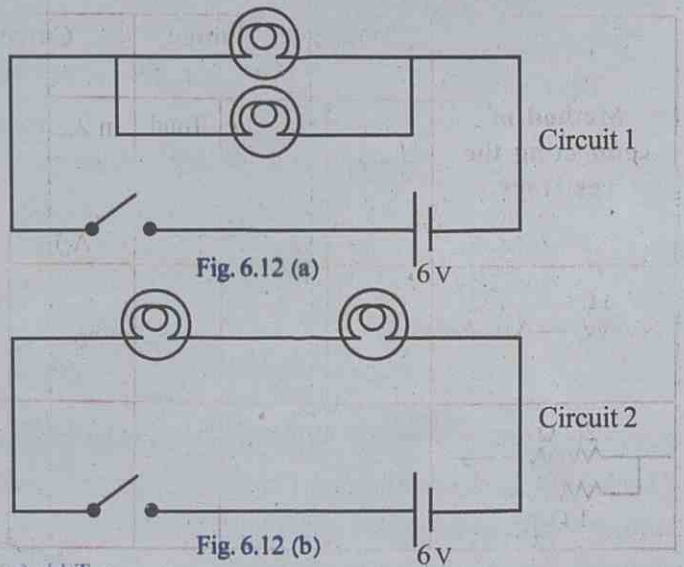

- In which circuit does the bulb glow with high intensity?
- Remove one bulb from each circuit. What do you observe?
 In Circuit 1:
 In Circuit 2:
- Why do the bulbs in Circuit 1 glow with maximum brightness? Draw suitable circuit with ammeter and voltmeter in the circuit, replacing the bulbs by $1\ \Omega$, $2.2\ \Omega$ resistors. Compare the circuit you have drawn with the one given below and construct it properly. Record the readings in the table.

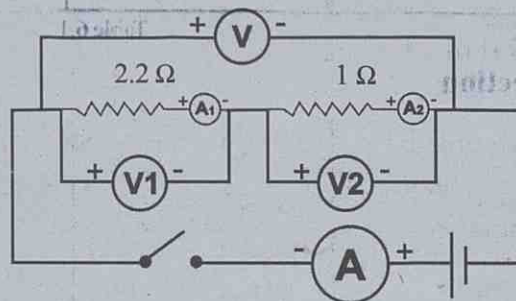

Fig. 6.13 (a)

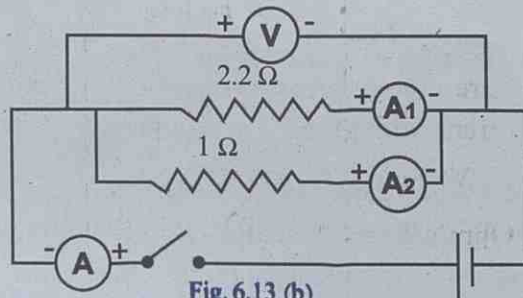

Fig. 6.13 (b)



See the section
KtechLab in PhET in the
IT @ School Edubuntu.

Method of connecting the resistors	Voltage obtained (V)			Current through resistors			Effective resistance (Based on current)
	For 2.2Ω V_1	For 1Ω V_2	Total V	In 2.2Ω I_1 (Through A_1)	In 1Ω I_2 (Through A_2)	Through A I	Increases/decreases
							
							

Table 6.9

Analyse the table and tick mark (\checkmark) the correct ones.

Method of connecting the resistors	Effective resistance	Voltage obtained for each resistor	Current through each resistor
	increases/ decreases	same/ different	same/ different
	increases/ decreases	same/ different	same/ different

Table 6.10

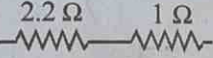
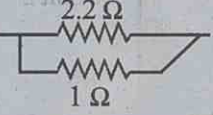
Series connection

The circuit is completed by connecting the resistors one after the other. This is series connection. When resistors are connected like this, the effective resistance increases.

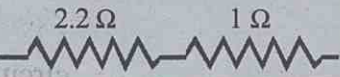
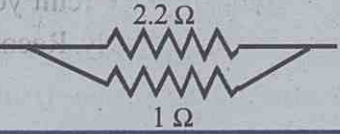

Fig. 6.14

When resistors are connected in series the potential difference gets divided. The current through each resistor is the same. Hence

$$V = V_1 + V_2, V_1 = IR_1, V_2 = IR_2$$

According to Ohm's Law, $V = IR$. Here R indicates the effective resistance.

Colour code

The value of resistance of carbon resistors available in the market has their resistance directly marked on them or indicated using colour codes. Usually rings of four different colours are used. The first two rings indicate the two digits, the third one indicates the number of zeroes and the fourth ring indicates tolerance (*deviation*). Silver $\pm 10\%$, gold $\pm 5\%$, and if there is no fourth line, then $\pm 20\%$ deviation will be there.



For example, if the first two rings are red and violet, then the first two digits are 2 and 7. The third one denotes the number of zeroes. If this is orange, then there are three zeroes. Now the value is 27000Ω . If the silver ring is also considered then the value = $27 \text{ k}\Omega \pm 10\%$.

Colour	Number	No. of Zeros
Black	0	0
Brown	1	1
Red	2	2
Orange	3	3
Yellow	4	4
Green	5	5
Blue	6	6
Violet	7	7
Grey	8	8
White	9	9

Now our journey is impossible.



Oh, We have to cross three bridges to reach the other side. Very difficult. Just as the resistors in series.

Hence

$$IR = IR_1 + IR_2$$

$$IR = I(R_1 + R_2)$$

$$R = R_1 + R_2$$

Effective resistance is the sum of the resistance of all the resistors when they are connected in series. If the resistors are of the same value then the effective resistance can be obtained by multiplying the resistance of a resistor with the number of resistors.

Parallel Connection

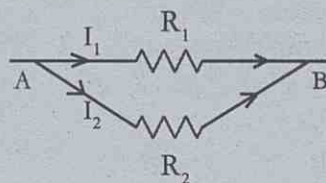

Fig. 6.15

The current completes the circuit by getting divided into each branch since the resistors are connected in parallel. The total current in the circuit is the sum of the current through all the branch circuits.

$$\text{Hence } I = I_1 + I_2$$

Since R is the effective resistance,

By Ohm's Law $\frac{V}{R} = \frac{V}{R_1} + \frac{V}{R_2}$

$$V\left(\frac{1}{R}\right) = V\left(\frac{1}{R_1} + \frac{1}{R_2}\right)$$

$$\frac{1}{R} = \frac{1}{R_1} + \frac{1}{R_2}$$

$$R = \frac{R_1 R_2}{R_1 + R_2}$$

If resistors of the same value are connected in parallel, then $R = \frac{r}{n}$, where n is the number of resistors and r is the resistance of one resistor.

Complete Table 6.11 by analysing Tables 6.9 and 6.10.

Resistors in series	Resistors in parallel
<ul style="list-style-type: none"> • Effective resistance increases 	<ul style="list-style-type: none"> •
<ul style="list-style-type: none"> • 	<ul style="list-style-type: none"> • The current through each resistor is different. It gets divided as per the value of resistors.
<ul style="list-style-type: none"> • The potential difference across each resistor is different. It gets divided as per the value of resistors. 	<ul style="list-style-type: none"> •
<ul style="list-style-type: none"> • 	<ul style="list-style-type: none"> • Each resistor can be controlled by using separate switches.

Table 6.11

- What is the current if 4Ω and 2Ω resistors are connected in series and 6 V potential difference is applied.

$$\begin{aligned} V &= 6 \text{ V} \\ R &= R_1 + R_2 \\ &= 4 + 2 = 6 \Omega \end{aligned}$$

$$R = \frac{V}{I}$$

$$6 = \frac{6}{I}$$

$$\text{Current } I = \frac{6}{6} = 1 \text{ A}$$

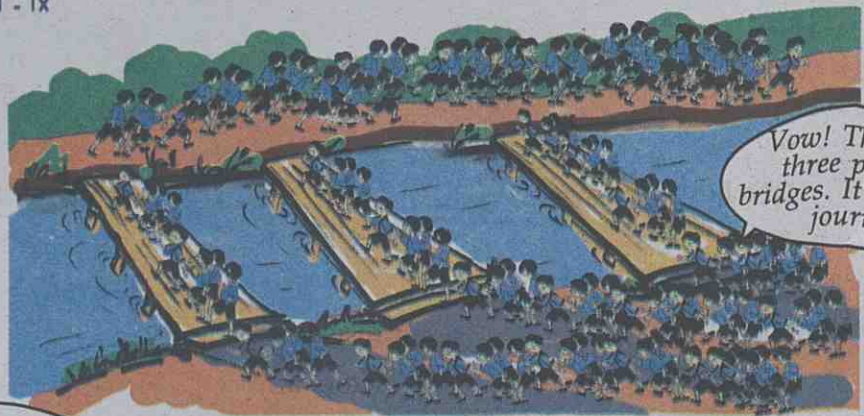

Even though one bridge has broken down, the journey is not affected. But the difficulties have increased.



- What is the current if 12Ω and 4Ω resistors are connected in parallel and 12 V potential difference is applied?

$$R_1 = 12 \Omega, R_2 = 4 \Omega, V = 12 \text{ V}$$

$$\frac{1}{R} = \frac{1}{R_1} + \frac{1}{R_2}$$

$$\frac{1}{R} = \frac{1}{12} + \frac{1}{4} = \frac{4 + 12}{12 \times 4} = \frac{16}{48}$$

$$R = \frac{48}{16} = 3 \Omega$$

$$\text{Current } I = \frac{V}{R} = \frac{12}{3} = 4 \text{ A}$$

$$V = 12 \text{ V}$$

$$R = \frac{R_1 R_2}{R_1 + R_2}$$

$$= \frac{12 \times 4}{12 + 4}$$

$$= \frac{48}{16} = 3 \Omega$$

OR

$$\text{Current } I = \frac{V}{R} = \frac{12}{3} = 4 \text{ A}$$

- 10 resistors of 2Ω each are connected in parallel. Calculate the effective resistance.

Now can't you solve the problem faced by the child at the beginning of the lesson? The brightness of the lamp increased because the current through each lamp had increased in the parallel connection.



Significant Learning Outcomes

The learner can

- describe how continuous flow of current is maintained in a circuit.
- describe potential difference, current and emf, and measure each using suitable devices.
- distinguish between resistance and resistivity and explain them.
- describe through experiments the factors affecting the resistance of a conductor.
- explain Ohm's Law and recognise the relation between potential difference, current and resistance by constructing circuits.
- calculate the effective resistance by constructing circuits in parallel and series.
- solve numerical problems connected with potential difference, current and resistance.



Let us assess

1. Complete the table properly

Component	Measuring device	Unit	
potential difference		$\frac{\text{joule}}{\text{coulomb}}$	
	ammeter		ampere

2. Given below are the diagrams showing the connection of ammeter and voltmeter in a circuit. Of these, which are correct?

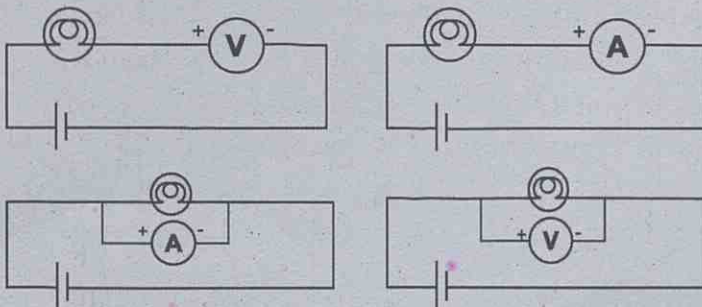

3. The resistance of a 10 cm long wire is 12Ω . If this is folded into two parts of equal length and included in a circuit, how much will be the resistance produced?

4. Of the following, which one correctly indicates Ohm's Law?

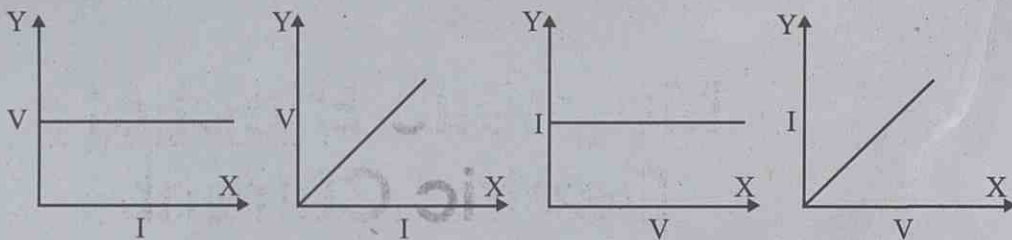

5. A potential difference of 6 V is applied across a conductor having 12 Ω resistance. How much current will pass through it?

How many times will the current increase if length of the resistor is halved and potential difference is doubled?

6. What mode of connection of three resistors of 3 Ω each will produce minimum resistance? What will produce maximum resistance? Draw the diagram and calculate the effective resistance.



Extended activities

1. Draw the method of connecting four resistors of 2 Ω each to get $\frac{10}{3} \Omega$.
2. The figure shows a conductor of resistance 8 Ω connected in a circuit in the circular shape.

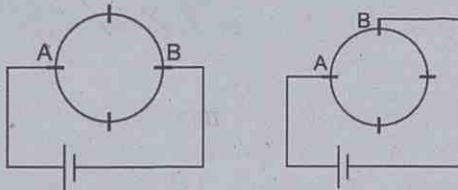

Of these, which gives minimum resistance? Justify your answer.

3. Construct a pencil rheostat as shown in the figure. Arrange a science corner to exhibit a model using this to show the factors affecting the resistance of a conductor and to explain Ohm's Law.

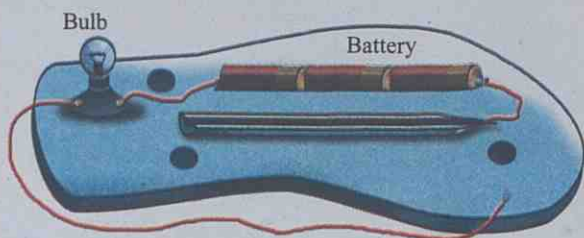

Make a channel on the sole of a slipper so as to place three cells. Remove the wooden insulation from half the pencil length wise so that the graphite can be seen. Fix a bulb holder and the pencil on the sole using glue. Then arrange clips, safety pin, cells and bulb as shown in the figure.



Magnetic Effect of Electric Current

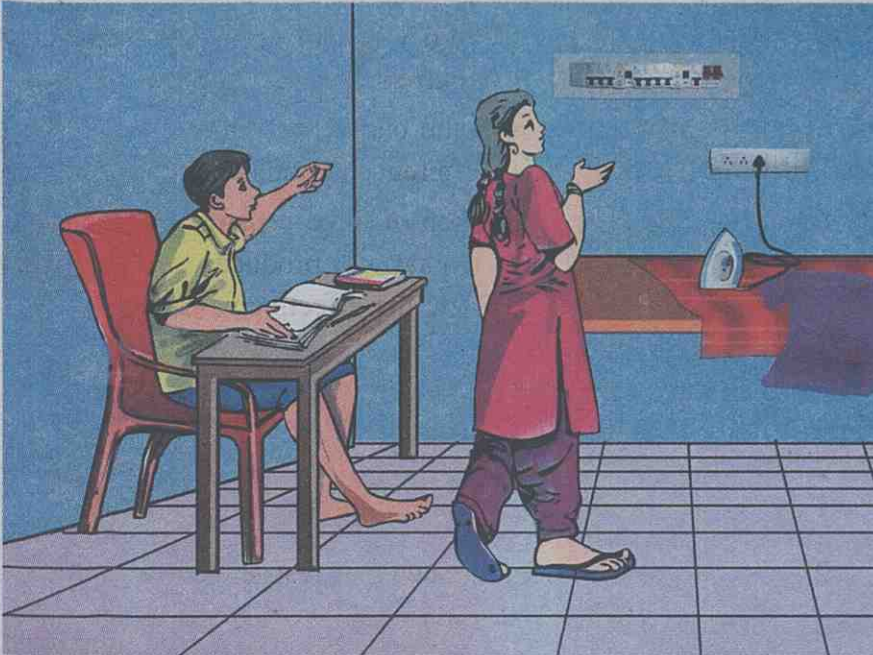

Seena : Power went off when the iron box was switched on.

Babu : If the MCB went off, put it on.

Seena : I am not able to switch it on.

Babu : The iron box might have gone out of order. Remove it from the circuit and switch on the MCB.

Seena : Oh! It is alright now. How does this MCB work?

Did you notice the doubt of the girl?

Let's examine it in detail.

Have you ever tried making electromagnets?

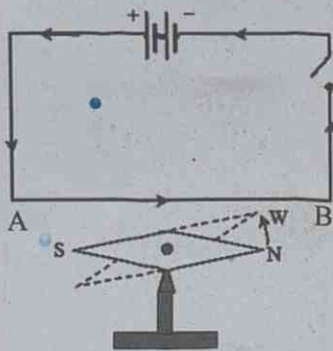

Fig. 7.1 (a)

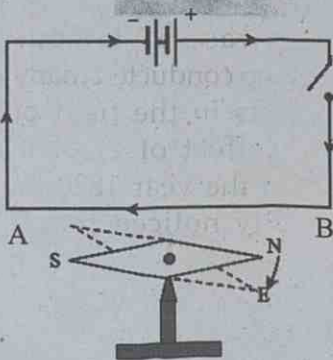

Fig. 7.1 (b)

Let us examine the magnetic field developed around a conductor carrying electric current.

Arrange a circuit above a pivoted magnetic needle in such a way that the part AB of the conductor is parallel and close to the magnetic needle, as shown in Fig 7.1 (a).

Switch on the circuit.

- Observe the direction in which the north pole of the magnetic needle deflects. Which is the direction of the electric current in the circuit? From A to B / from B to A.

Repeat the experiment after reversing the current and record your observations in the table.

No.	Conductor above the magnetic needle	Direction of motion of north pole (N) of the magnetic needle
1	Direction of current from A to B	clockwise/ anti clockwise
2	Direction of current from B to A	

Table 7.1

Repeat the experiment keeping the conductor below the magnetic needle and record the observations in the table.

No.	Conductor below the magnetic needle	Direction of motion of north pole (N) of the magnetic needle
1	Direction of current from A to B	clockwise/ anti clockwise
2	Direction of current from B to A	

Table 7.2

Analyse the findings obtained from the experiments.

- What might be the reason for the deflection of the magnetic needle?

Ampere's swimming rule

Imagine a person swimming along a conductor in the direction of current facing a magnetic needle. The north pole of the magnetic needle deflects towards his left hand.





Hans Christian Oersted (1777-1851)



Oersted was a famous scientist who conducted many experiments in the field of magnetic effect of electric current. In the year 1820 he accidentally noticed that a magnetic needle kept near a current carrying conductor experienced deflection. Thus the unbreakable relation between electricity and magnetism was realised for the first time. His experiments marked the beginning of the technology behind the devices like radio, TV, fibre optics etc., used today. As a mark of respect to him, the unit of intensity of magnetic field has been named after him.

We have already studied that a magnetic field exerts force on magnets. In this case, the magnetic field must have produced the force required to move the magnetic needle. How is this magnetic field produced? Think it over.

A magnetic field is developed around a current carrying conductor. The magnetic needle is deflected as a result of the mutual action of this magnetic field and that around the magnetic needle.

Insert a conductor through the centre of a cardboard as shown in the figure and pass current through it. Using a magnetic compass or magnetic needle, draw the lines of force around the conductor. Try to relate the direction of current and the direction of lines of force.

The relation can be found out as shown in the figure.

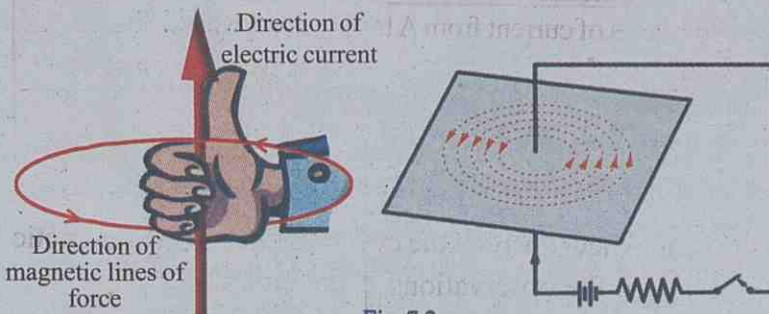

Fig. 7.2

Right hand (Thumb) Rule

Imagine you are holding a current carrying conductor with the right hand in such a way, that the thumb points in the direction of the current. The direction in which the other fingers encircle the conductor gives the direction of the magnetic field. This is the Right hand Thumb Rule.

Suppose the current carrying conductor is given a circular shape. Let's try to draw the magnetic lines of force.

Insert the two ends of the conductor through a card board as shown in the figure and pass current through it.

Draw the lines of force (Fig 7.3). Observe the direction of lines of force between the points where the conductor is passing through the card board.

Are they not passing in the same direction?

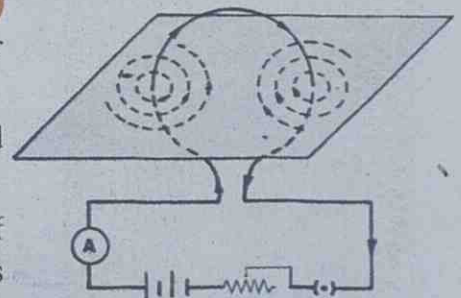

Fig. 7.3

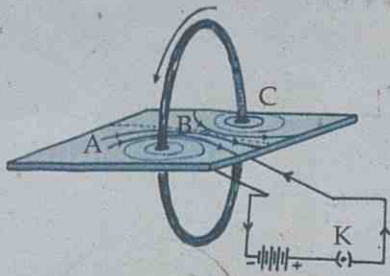

Fig. 7.4

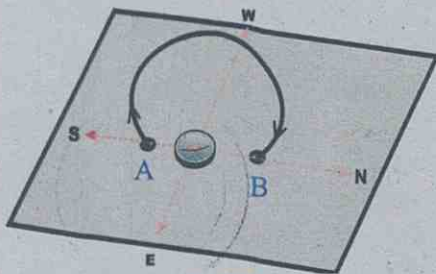

Fig. 7.5

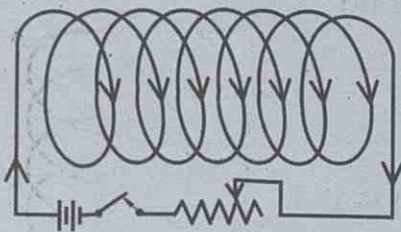

Fig. 7.6

Magnetic lines of force

Magnetic lines of force is only an indicator of a magnetic field.

- If the electric current passes in the clockwise direction, the magnetic lines of force appear to move away from us into the coil through the central part of the coil. What happens when current is in the anti-clockwise direction?

Let's repeat the experiment by increasing the number of turns of the coil.

Try the experiment by increasing the length of the conductor and number of turns as shown in Fig. 7.4.

Did the intensity of the magnetic field increase?

Keep a current carrying circular conductor vertically in the north south direction. The magnetic field produced will be in the east west direction. Draw a line perpendicular to the line joining the points A and B. Move the compass through this perpendicular line at the centre of the coil in both directions. When the magnetic effect of the coil vanishes, the magnetic needle comes in the north south direction.

Measure the distance between these points on either side of the coil. Perform this experiment by increasing the number of turns of the coil and see how far the magnetic needle remains in the east west direction on either side. Now the distance between the two points increases. Is it not due to the increase in the strength of the magnetic field? (Ensure that the electric current is the same in both cases).

When the number of turns of the coil is increased, the strength of the magnetic field increases.

Solenoid

Observe a conductor wound as shown in the figure. Doesn't it look like a spring? Solenoid is a conducting coil wound in the shape of a spring.

- What is the nature of the magnetic field that is developed when an electric current is passed through the solenoid?

A strong magnetic field is developed by the combination of lines of force around adjacent turns of the coil.

Compare the lines of force formed around a solenoid carrying current with the lines of force around a bar magnet.

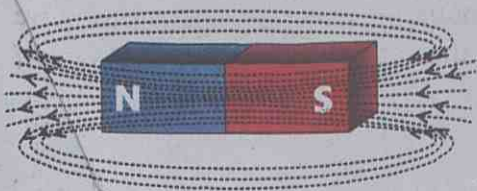

Fig. 7.7 (a)

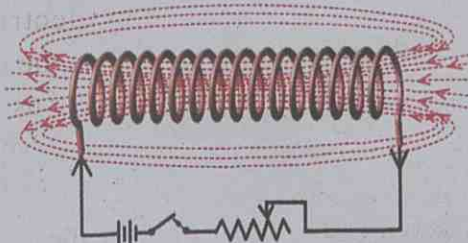

Fig. 7.7 (b)

Aren't the lines of force around a solenoid identical to those around a bar magnet?

A current carrying solenoid acts like a bar magnet.

How will you find out its poles?

Try to find out the poles of a solenoid using a compass needle.

There is an easy way for finding out the poles.

Imagine the solenoid being held by the right hand. If the four fingers encircling the solenoid show the direction of current, the thumb indicates the north pole.

The polarity of the solenoid can be found out in yet another way.

Hold a solenoid against your face. Note the direction of current at one end of the solenoid. If the direction of current at one end is in clock wise direction what will be the direction at the other end?

The end of the solenoid at which current flows in the clock wise direction will be the south pole and the end at which current flows in the anti clockwise direction will be the north pole.

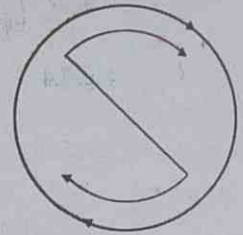

Current in clockwise direction

Fig. 7.8 (a)



Current in anti-clockwise direction

Fig. 7.8 (b)

- Observe Fig. 7.9. When a current is passed through the circuit,

Polarity at A =

Polarity at B =

- What was used as the core of the electro magnet you had constructed in an earlier class?

- Which quality of soft iron did you make use of in this case?

- Using soft iron as core, pass an electric current through the solenoid. Note the change in the magnetic strength and record the same.

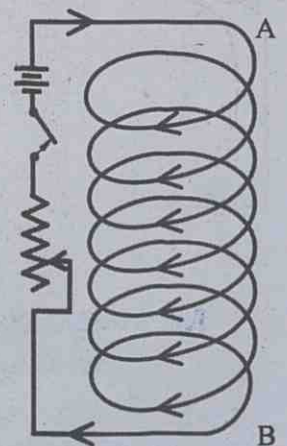

Fig. 7.9



Relay switches

The relay switches work making use of the magnetic effect of electric current. In heavy vehicles, starting motors are used to start the engine. For the working of a starting motor, electric current of large intensity is required. It is very difficult and expensive to connect the required electric circuit to a switch which works using a key. Therefore, a key is used to work a circuit having low electric current. A piece of soft iron is magnetised using this current. The magnet attracts another piece of soft iron, thereby completing another circuit and provides electricity required for the starting of the motor. On starting the vehicle, the second switch is switched off and the electric current ceases to flow. This is one mode of working of the relay switch. In the new age, electronic relay switches are used.

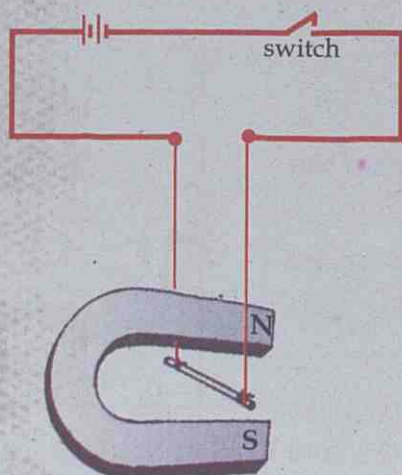

Fig. 7.11

- What happens when the current through the solenoid is increased? Write it down.

Repeat the experiment by increasing the number of turns of the solenoid.

- Now you have understood the ways of increasing the magnetic strength of solenoid carrying current. Try to write it down.

Now let's see the working of MCB referred by Seena.

When there is an excess flow of current through the circuit in which MCB is included, a strong magnetic field develops around it. At this time, the coil attracts a piece of soft iron. The piece of iron moves and makes the switch of MCB work, thereby breaking the circuit. MCB works, making use of the magnetic effect of electric current.

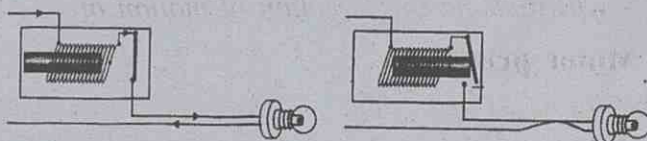

Fig. 7.10

You have observed the deflection of a magnetic needle kept near a current carrying conductor. But, have you ever thought of the force on a current carrying conductor kept near a fixed magnet?

Let's do an experiment.

A copper wire is suspended between the pole pieces of a U shaped magnet, using thin conductors in such a way that the wire is perpendicular to the magnetic field and it is free to oscillate in the magnetic field. This conductor is connected to a battery through a switch. When the switch is put on,

- What happens to the position of the copper wire?
- What happens when the switch is turned off?
- What happens when the current in the circuit is reversed?
- Repeat the experiment by interchanging the magnetic poles.

What would be the reasons for the observations made?

Write down your inference about the force experienced by the conductor kept in the magnetic field.

The current carrying conductor kept in a magnetic field experiences a force. This force depends on the direction of the current and the direction of magnetic field. This force is not experienced when current flows in the direction of the magnetic field.

Can you find out the direction of motion of a current carrying conductor kept in a magnetic field?

Fleming's left hand rule

Hold the forefinger, middle finger and thumb of the left hand in mutually perpendicular directions as shown in the figure. If the forefinger indicates the direction of the magnetic field and the middle finger, the direction of the current, then the thumb will indicate the direction of motion of the conductor.

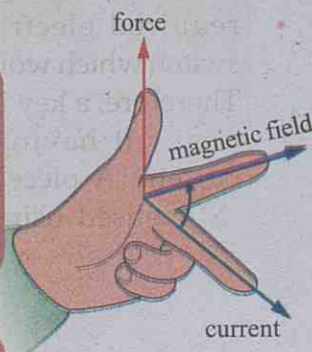
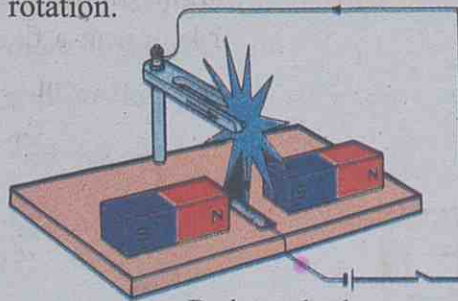

Fig. 7.12

Motor principle

A conductor which can move freely and which is kept in a magnetic field experiences a force when current passes through it.

Observe the figure. Write down the reason for the rotation of the wheel and mark the direction of rotation.



Barlow wheel

Fig. 7.13

In the experiments which we have done, the current carrying conductor kept in the magnetic field moves. It is the electrical energy that provided the mechanical energy required for the motion of the conductor.

Write down the change of energy here.

 What is the name of the device which converts electrical energy into mechanical energy?

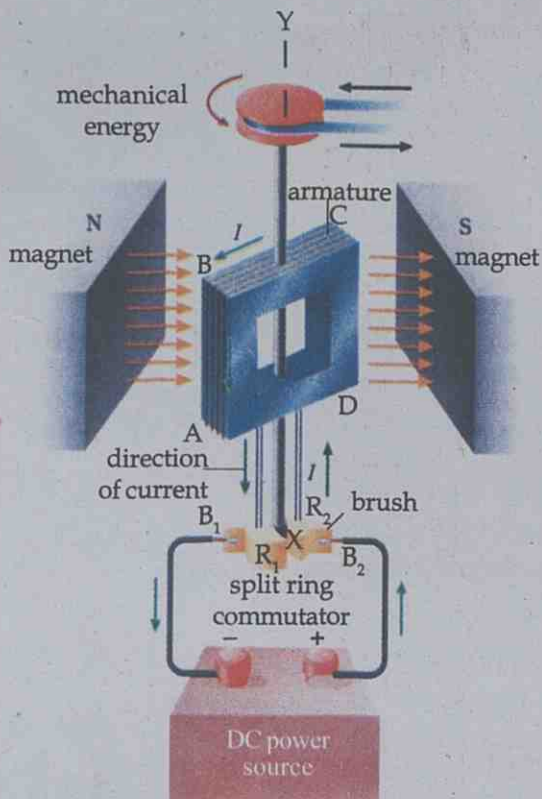

DC electric motor
Fig. 7.14

Electric motor

Note the parts of an electric motor shown in the figure.

- NS – Magnetic poles
- XY – Axis of rotation of the motor
- ABCD – Armature
- B_1, B_2 – Graphite brushes
- R_1, R_2 – Split rings

Armature

Armature is the metallic coil wound round a soft iron core so that it is free to rotate. It is fixed firmly in the axis XY. In the figure, are the forces acting on sides AB and CD in the same direction? Find out on the basis of Fleming's left hand rule and write it down. What are the effects produced by forces thus developed on the armature?

The split rings help to change the direction of current through the coil after every half rotation. For this reason it is also called split ring commutator.

Moving coil loud speaker is a device that works on the basis of motor principle

Moving coil loud speaker

Observe the picture showing the structure of a loud speaker.

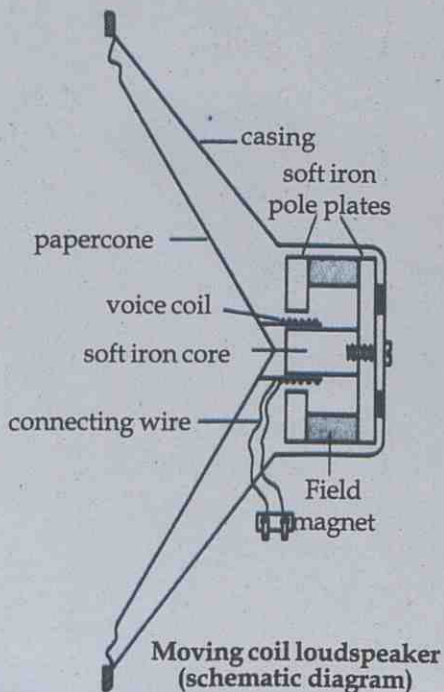

Moving coil loudspeaker (schematic diagram)
Fig. 7.15

- Where is the voice coil situated?

- To which arrangement is the paper cone connected?

- From where does the electric current reach the voice coil?

- What happens when current is passed through the voice coil?

The electrical pulses from a microphone are strengthened using an amplifier and sent through the voice coil of a loud speaker. The voice coil, which is placed in the magnetic field, moves very fast to and fro, in accordance with the electrical pulses. These movements make the paper cone vibrate, thereby reproducing sound.

Now you have understood the relation between electricity and magnetism. Can magnetic power be used for the production of electricity? You will learn more about this in higher classes.



Significant Learning Outcomes

The learner can

- draw the magnetic lines of force around a current carrying conductor.
- draw lines of force around a conductor bent into the form of a coil and find out the direction of the magnetic field.
- determine the polarity of a solenoid carrying current.
- explain and prepare notes about the structure, working principle of a motor and change of energy associated with an electric motor.
- explain the structure and principle of the working of a loud speaker.



Let us assess

1. Current is passed from south to north through a conductor placed below a freely pivoted magnetic needle.
 - a) To which direction will the north pole of the magnetic needle turn?
 - b) Which is the rule used to arrive at this inference?
 - c) State the rule.
 - d) If the current flows in the conductor in the east west direction, what do you guess about the deflection of the magnetic needle? Explain.
2. How will you determine the polarity when current is passed through a solenoid? Suggest methods for increasing the strength

of the magnetic field around a current carrying solenoid.

3. State the Motor Rule. If the directions of current in the conductor and the magnetic field are the same, in which way will the conductor move?



Extended activities

1. Construct a simple DC motor and show its working.
2. Draw the lines of force around a solenoid and exhibit it.
3. Dismantle the parts of a loudspeaker that is defunct and arrange them on a sheet of paper one by one and exhibit. What is the reason for its voice coil being very thin?
4. Draw a diagram of the structure of an electric motor, mark its parts and exhibit.

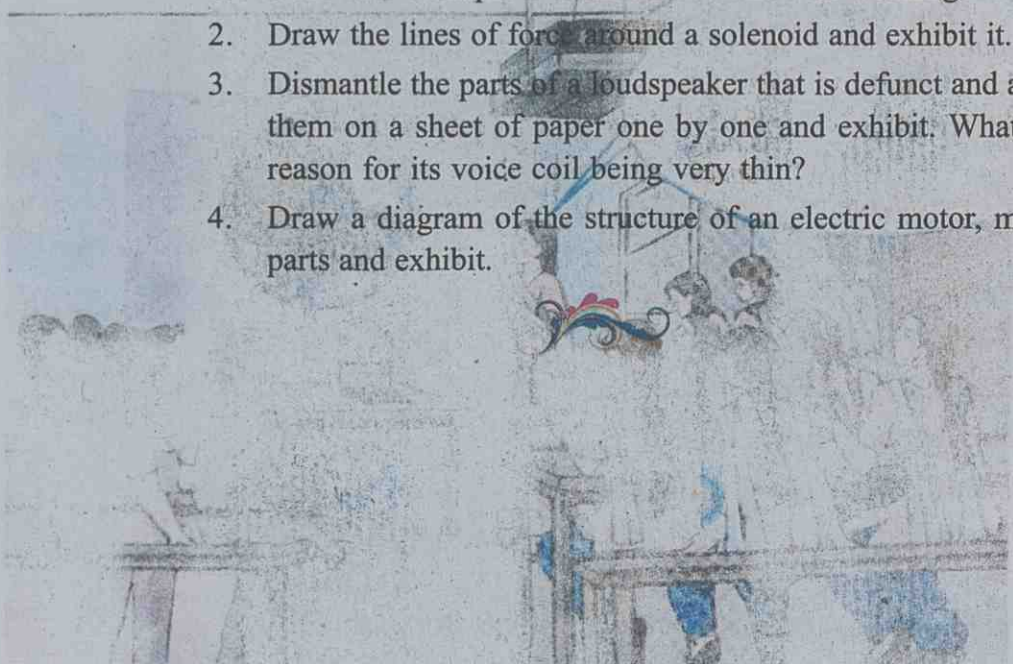

Our Universe

You know that only one side of the moon can be seen from the earth. But in this photograph, the other side of the moon is also seen. Is this not a proof of our successful space exploration?



Today we can see the other side of the moon not visible from the earth. This is an achievement of modern space exploration. How did our ancestors observe the sky?

You might have observed a clear night sky.

What a wonderful experience it is!

What all could you see there?

- Stars

-

Are all of them seen at the same spot on all days?

You are familiar with the change in the position and the shape of the moon each day.

At a time when there were no calendars, the positions of the moon, planets, the sun, and other stars were depended on to calculate time. This type of sky calendars was used for various purposes like timing of agricultural activities and recording of birth and death. Stars and days as per the sky calendars are still included in the modern calendars. Let's now find out how our ancestors made use of the moon's change of position.

Naal (Asterism)

- You know that the moon revolves around the earth with the stars at the background. How many days does the moon take to revolve once around the earth?
- If the moon completes a 360° circular path in about 27 days, how many degrees does it move in one day?

Therefore the path of the moon may be considered as 27 equal parts, each of an average $13\frac{1}{3}^\circ$.

The stars and the clusters of stars seen in these 27 parts, when viewed from the earth, are depicted in Fig 8.1. Observe it.

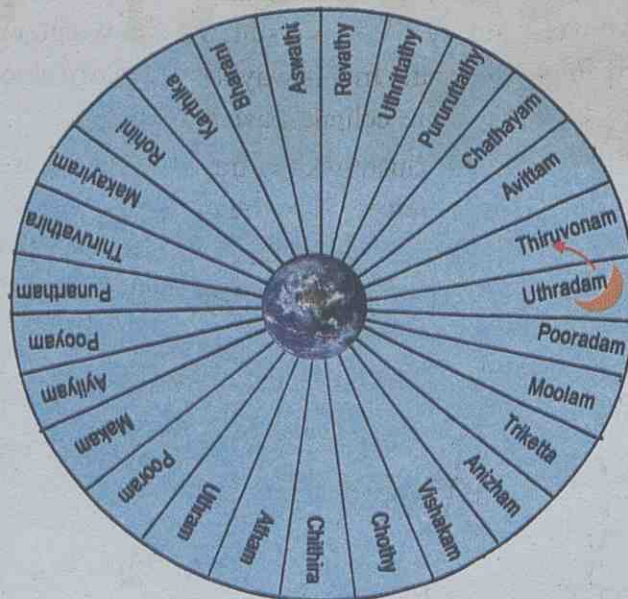

Fig 8.1

- In the background of which star is the moon seen?

- In the background of which star will be the moon the next day?

The time taken by the moon to move $1/27^{\text{th}}$ of its path of revolution is one asterism. The asterism on a day is known by the name of the star which comes as the background of the moon on that day.

Haven't you understood how *asterism* was formulated?

Examine the calendar and find out which *asterism* is today. Can this star/cluster be spotted in the sky? How?

In the olden days, there were no calendars. At that time *asterism* was used to mark important events and to name children.

For example,

- The *uthrattathi* boat race in the month of *Chingam*
- *Swathi* Thirunal

Now let's see how the months in Malayalam evolved. If you observe stars at a particular time (eg: 8 O'clock) in the night, you will be convinced that they move 1° westwards every day. Why is it so?

The earth requires $365 \frac{1}{4}$ days for revolving once around the sun. A change in position at the rate of about 1° per day takes place for the earth. Owing to this revolving motion of the earth around the sun, for an observer on the Equator, the stars in the background of the sun appear to move westward by 1° . As a result, the sun would appear to move eastward among the stars. In this way the trajectory along which the sun appears to move is the ecliptic (*kranthivrutham*).

Observe the figure. Fig 8.2 illustrates the trajectory along which the sun appears to move when viewed from the earth.



IT @ School
Edubuntu -
refer Stallarium

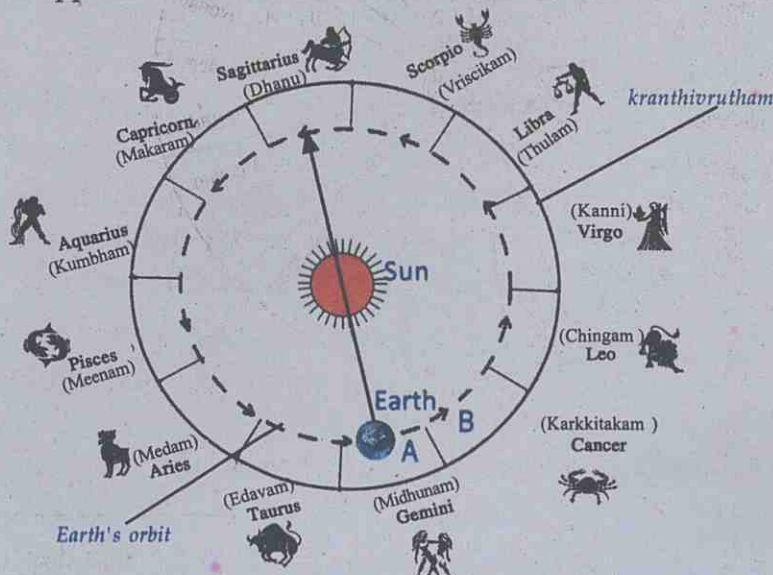

Fig 8.2

Zodiac

Ecliptic (*Kranthivrutham*) may be imagined as a tape drawn on the sky at a total width of 18° on both sides of the Zodiac (*rasichakram*). The zodiac is divided into 12 equal parts. These are called solar constellation. Each zodiac is known by the name of the respective constellation.



How is a star chart used for observing stars?

Choose an open ground or the top of a high building from where the entire horizon can be seen in the night. Lie there on your back with your head towards the north, holding the star map according to the directions indicated in it. You will be able to identify the important stars easily.

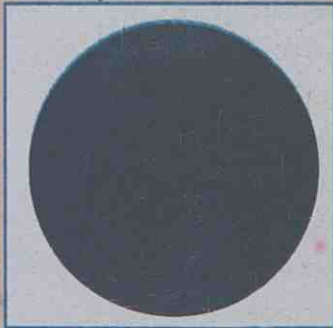

- Into how many parts is the Ecliptic divided ?

If so, will it not be 30° in each part?

- In Fig 8.2, if the earth is at 'A', in which zodiac does the sun appear?
- When does the earth reach 'B'?

Each Malayalam month is known by that zodiac which appears as the background of the sun when viewed from the earth. The sun requires approximately 30 days for crossing a zodiac.

- In the month of *Karkkitakam* in which zodiac will the sun be?
- With the help of a star chart, find the zodiac seen above your head at 12 O'clock at night in the month of *Makaram*.

Njattuvela

The changes in the position of the moon and the sun were made use of to formulate *asterism* and the Malayalam months. Their position was made use of in agricultural activities in a similar way.

When the Zamorin came to know that foreigners were taking away pepper vines along with pepper to their country, his response was this:

"They can take away only the pepper vines, but not *thiruvathira njattuvela*."

What is this *njattuvela*?

Observe the figure.

The earth completes one revolution around the sun in $365 \frac{1}{4}$ days. During this interval the sun would have passed through 12 zodiacs and 27 asterisms.

- If so, approximately how many days would be required for the sun to pass one zodiac?

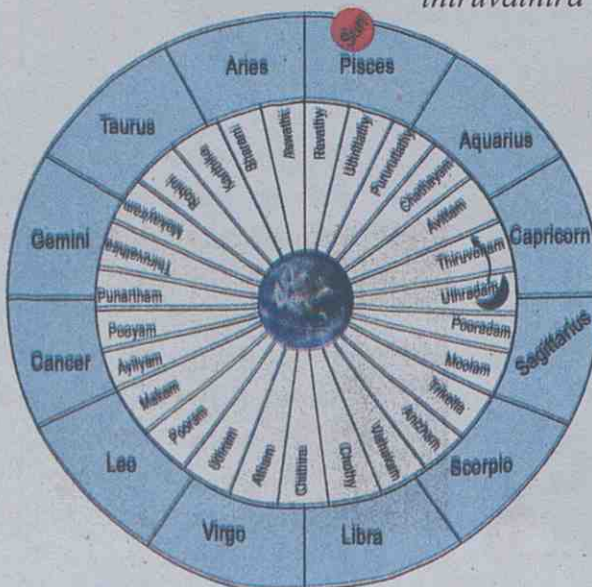

Fig 8.3



Proverbs related to *Njattuvela*

Njattuvela sayings	Related njattuvela	Approximate time
<i>Karthika Karivattakam pole</i>	<i>Karthika</i>	April 14 -28
<i>Makeeryathil mazha mathimarannu</i>	<i>Makeeram</i>	June 8 - 21
<i>Thiruvathirayil mazha thirimuriyathe</i>	<i>Thiruvathira</i>	June 22 - July 5
<i>Punarthathil puzhathoni vilangilla</i>	<i>Punartham</i>	July 6 - 19
<i>Pooyathil mazha puzhayerinjapole</i>	<i>Pooyam</i>	July 20 - August 2
<p><i>The puthumazha (new rain) during Karthika njattuvela became very dear to Keralites.</i></p> <p><i>The incessant rain in Thiruvathira njattuvela helps to get good harvest due to increased pollination.</i></p>		

Njayar means the sun and *njayarinte vela* means time with the sun.

Njattuvela is the duration of time the sun is seen along with an asterism. The duration of a njattuvela is approximately 14 days.

For the estimation of time, counting of zodiacs begins with Aries and the asterism with Aswathy.

- *Thiruvathirayil thirimuriyatha mazha* is a famous *njattuvela* saying in Kerala. Find the crux of the Zamorin's saying based on this.

What are the other purposes for which our ancestors observed the stars?

- To find out direction
-

In earlier classes, you had studied the use of the constellation *Vettakkaran* (Orion) to find directions.

Constellation

Saptharshikal or the Big Dipper is another constellation used to find out direction.

Each constellation was named after known shapes of objects. The seven stars having comparatively good brightness seen continuously in the sky, were compared with seven saints (*saptharshikal*). Foreigners compared it with a big spoon and called it the Big Dipper.



Fig 8.4

With the help of star charts, observe the sky and study the other constellations.

The Sun

The Sun is a glowing gaseous sphere. About 500 crore years have passed since it started glowing in this state.

Matter exists in the plasma state in the sun. The core of the sun is at a temperature of 1.5 crore kelvin and has enormous pressure. The energy produced here in the form of gamma rays comes out through the radiation zone after absorption and re-emission for several times. The convection zone outside the radiation zone receives this energy and transfers it to photosphere through the convection process. From there it comes out as sun rays.

The thin regions of chromosphere outside the photosphere and the vast outermost region, corona are considered as the atmosphere of the sun.

Another phenomenon seen in the sun is sunspots. They are seen as black spots on the surface of the sun and are relatively low temperature regions. Sun spots are also the source of strong magnetic field.

From the surface of the sun, a large flow of nuclei of hydrogen and helium occurs continuously. This is the solar wind.



Energy production in the stars

Combustion is a chemical reaction in which a fuel or other substances combine with oxygen. But in the stars, the energy production process is not a chemical reaction. It takes place through nuclear fusion of nuclei. In the first stage of energy production in stars, hydrogen nuclei combine together to form helium nuclei. In this process matter is converted into energy.

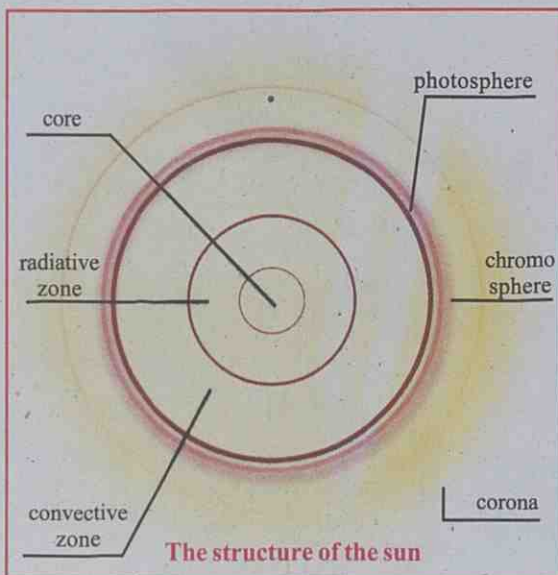

Fig 8.5 (a)

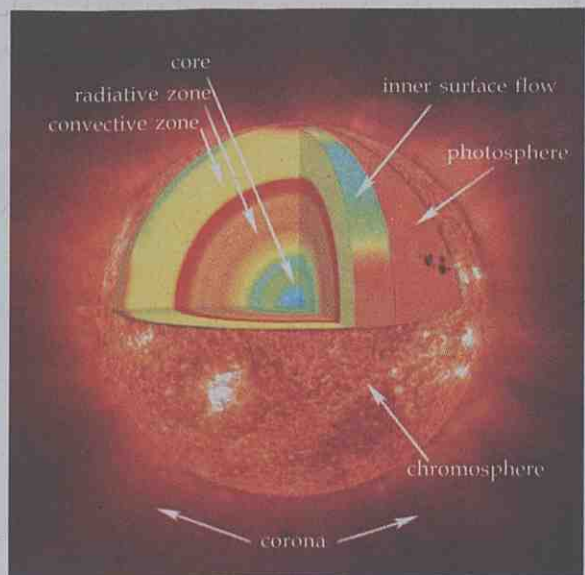

Fig 8.5 (b)

At times, huge flames rise up and fall back in the form of an arch on the surface of the sun. They are known as solar prominences.

Energy is produced in the sun due to nuclear fusion. Four hydrogen nuclei combine together to form a helium nucleus and in this process, a large amount of energy is released.

- Why does matter exist in plasma state in the sun?
- Corona is seen only during solar eclipse. Why?
- What are the ways in which energy from the core reach the photosphere?
- Do all stars have the colour of the sun?

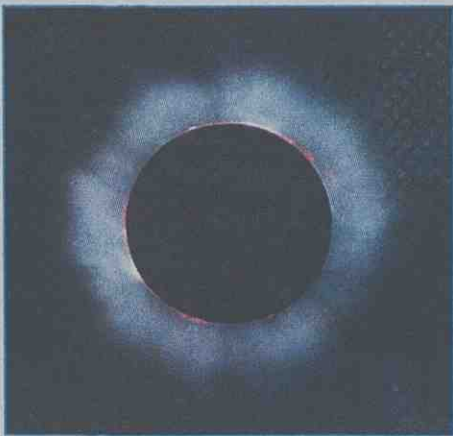

Fig 8.6 (a) Total solar eclipse

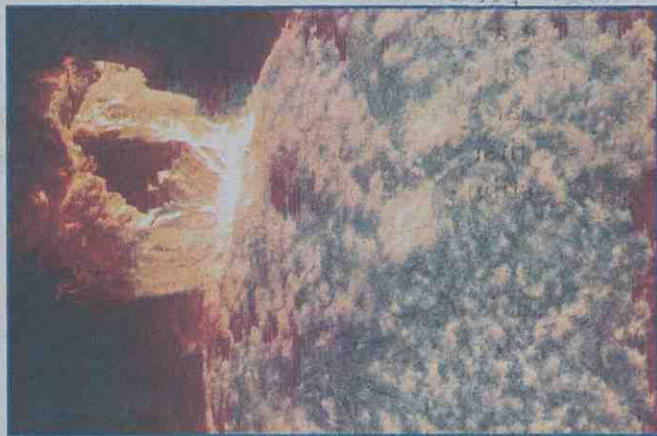

Fig 8.6 (b) Solar prominences

Observe carefully. The colour diversity of stars will amaze us. Stars of so many different colours! Blue, white, yellow, orange, red, etc. What is the reason for this colour difference?

The surface temperature determines the colour of the stars. The stars at high temperature appear in blue colour and those at the lowest temperature appear in red colour. Some stars and their colours are given in the table. Expand the table.

Colour	Blue	Yellow	Orange	Red
Stars	Regal	Sun	Chothi	Thriketta Makayeeram Rohini Thiruvathira

Table: 8.1 Stars and their colours

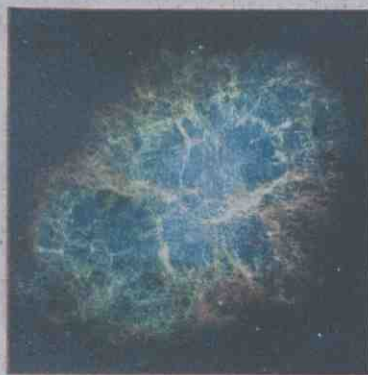

Fig 8.7 Crab nebula



Fig 8.8 Orion nebula

Those in red colour are older and those in blue colour are younger. Thus we can understand that all stars were not born at the same time.

How were the stars born?

Birth and death of stars

Stars are born in gaseous clouds in interstellar space. They are also known as nebulae. Gases like hydrogen and helium, and small amounts of some other elements are present here. The contraction of gas clouds by the gravitational force of attraction in nebulae is the beginning of the birth of stars. Owing to high gravitational attraction, the kinetic energy of the gas cloud increases and heat is produced. This causes fusion in the core. The heat due to fusion produces an outward pressure. The pressure due to gravitational force gives rise to an inward pressure. When there is equilibrium between these two pressures, the birth of the star is complete. This helps to maintain the size of the stars for several crores of years.

- The formation of stars begins when the hydrogen atoms in nebulae start condensing due to gravitational attraction. If so, which nebula, one of greater mass or lesser mass, will reach the state of stars?

For some nebulae, the mass is low and they cannot attain sufficient temperature for fusion at the time of condensation. Hence all nebulae do not become stars.

- What will happen to the sun aeons later?

Won't the fuel in the core of stars be exhausted completely in the course of time?

The course of evolution from birth will be different for stars of different masses.

Sun-like stars

The sun and the stars having mass less than 1.44 times the mass of the sun, are sun-like stars. The stages from birth to the end of such stars are given in the first flow chart. The second flowchart depicts the evolution of stars of greater mass.

Sun-like stars

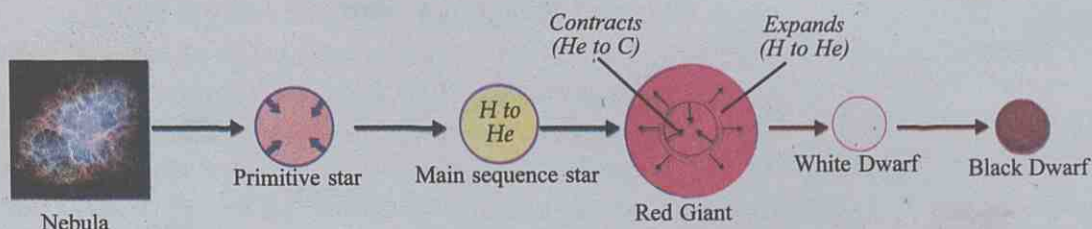

Flow chart - I

Massive stars

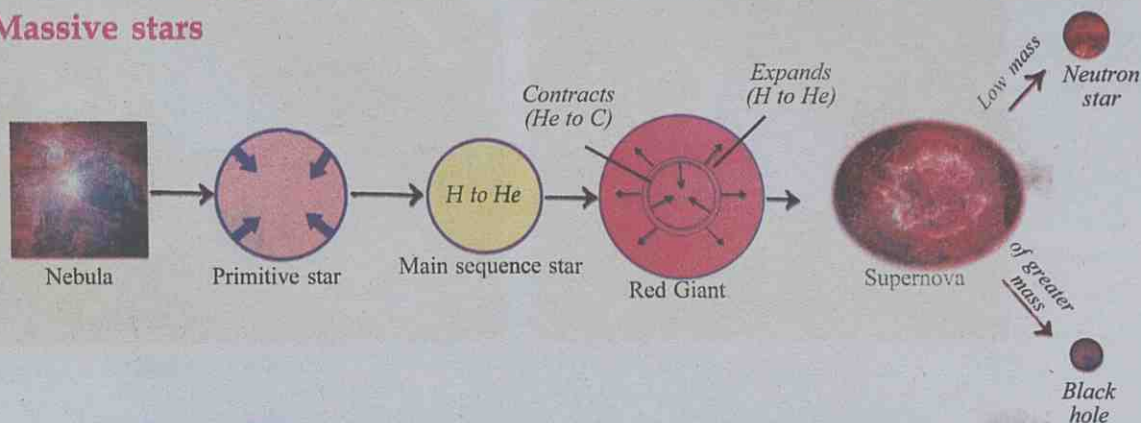

Flow chart - II

Fig 8.9

- Write the stages of evolution from the birth of the sun.
- You know the colour of the stars, Thriketta and Thiruvathira. At what stage of evolution are they now? Find out.
- Which will be the last stage of evolution of a star of the greatest mass?
- Explain the circumstances under which a star is transformed into a black hole and a neutron star.

Galaxies

On observing the clear sky at night, among the stars of different colours, we can see plenty of stars spread inside a long white cloud on the southern part of the sky. In September, it can be seen clearly. This is the central part of the Milky Way, the cluster of stars including our sun.



Subramanyan Chandrasekhar (1910-1995)



In the 1930s, while conducting research on stars, Chandrasekhar found out mathematically that the maximum mass of White Dwarf stars is 1.44 times the mass of the sun. This limit is crucial in the evolution of stars. This is known as *Chandrasekhar Limit*.

Several crores of stars, bound together by gravitational attraction, and interstellar matter, combine together to form a galaxy. A galaxy may contain 10 lakhs to several crores of stars. In the universe 100 billion such galaxies are assumed to be present. They rotate by themselves. Our galaxy contains 150 billion stars. Galaxies are in different shapes. The Milky Way is a spiral galaxy.



Spiral galaxy
Fig 8.10 (a)



Elliptical galaxy
Fig 8.10 (b)

- From one edge to the other edge of the Milky Way, the distance is one lakh light year. Let's calculate this distance in kilometers.

$$\begin{aligned}
 1 \text{ light year} &= 9.46 \times 10^{12} \text{ km} \\
 1 \text{ lakh light year} &= 100000 \times 9.46 \times 10^{12} \text{ km} \\
 &= 946000000000000000 \text{ km} \\
 &= 9.46 \times 10^{17} \text{ km}
 \end{aligned}$$

- What is the shape of the galaxy we live in ?
- The distance between our galaxy and the nearest galaxy Andromeda is 24 lakh light year.
How many years will a ray of light take from Andromeda to reach our galaxy?
- It is difficult to imbibe the infinite nature of the universe. What is our position in this universe? How did this universe come into being?

Origin of the universe

There are many hypotheses regarding the origin of the universe.

Among them, the Big Bang Theory is the one that has received wide acceptance from scientists.



Big Bang theory

The Big Bang Theory says that the whole of our universe was formed as a result of a huge explosion about 1,400 crore years ago. This theory has got wide acceptance.

Some inferences supporting the Big Bang Theory are:

- All galaxies are drifting away from one another.
- This separation is due to an explosion.

Space research in India



“There are some who question the relevance of space activities in a developing nation. But, for us, there is no ambiguity of purpose. We do not have any fantasy of competing with the economically advanced nations in the exploration of the moon or the planets or manned space flight. But we are convinced that if we are to play a meaningful role nationally, and in the community of nations, we must be second to none in the application of advanced technologies to the real problems of man and society”

Dr. Vikram Sarabhai

These are the words of Dr. Vikram Sarabhai, the Father of Indian Space Research. We are progressing by lending wings to his views and imagination. Let's review the progress.

- The formation of ISRO on 15 August 1969.
- On 19 April 1975 the first artificial satellite was put into orbit around the earth with the help of Soviet Union.
- Polar Satellite Launch Vehicle (PSLV) was developed. Polar Satellites were launched.
- Geosynchronous Satellite Launch Vehicle (GSLV) was developed. Launching of Equatorial Satellite was realized.
- Bhaskara series – Experimental distant sensing satellites
- Rohini series for space observation
- Stretched Rohini series for Space observation

Edwin P Hubble

The finding of famous astrophysicist Edwin Powell Hubble that the galaxies are drifting away from one another and that the distance between them and the speed of their separation are in direct proportion, have garnered strong support for the Big Bang Theory.

To reveal the secrets of the universe, man has made accurate and precise equipment. X-ray telescope Chandra, Hubble Space Telescope and Astrosat are some examples. Since the presence of scattered light on the earth would become an obstacle for observation, experimental equipment has to be installed outside the atmosphere of the earth.



Astrosat



Hubble telescope



Dream is not what you see in sleep; dream is the thing that does not let you sleep.

**Dr. A.P.J. Abdul Kalam
(1931 – 2015)**



Born on 15 October 1931 at Rameswaram in Tamil Nadu, Dr.Kalam started his career as a scientist in DRDO. He designed rockets and served in ISRO for 20 years. Dr.Kalam was a great man who proved to the world that our country too could carry out atomic programmes. He played an active role in the production of medium range ballistic missile such as Agni and Pridhvi. He is known as the Missile Man of India. He proved his genius as a teacher, scientist and the President of India. Many awards such as Padma Bhushan, Padma Vibhushan, Indira Gandhi Puraskar for National Integration, Ramanujan Puraskar, etc., were conferred on him. Honorary doctorate degrees were conferred on him by 40 universities. The nation honoured him with the Bharat Ratna in 1977. He liked communicating with students the most. His sudden demise was on 27 July 2015 while at a function in Shillong.

- Indian Remote Sensing Satellite (IRS) series– Remote sensing, meteorological purpose.
- Indian National Satellite series (INSAT) - Multipurpose projects, communications, meteorological studies.
- Chandrayan – Moon exploration – 22 October 2008
- Mangalyan – Mars mission – 5 November 2013
- Astrosat – 28 September 2015

Collect more information regarding our achievements in the field of space exploration and conduct a seminar. An artificial satellite helps in the study of space. What are the other uses of artificial satellites?

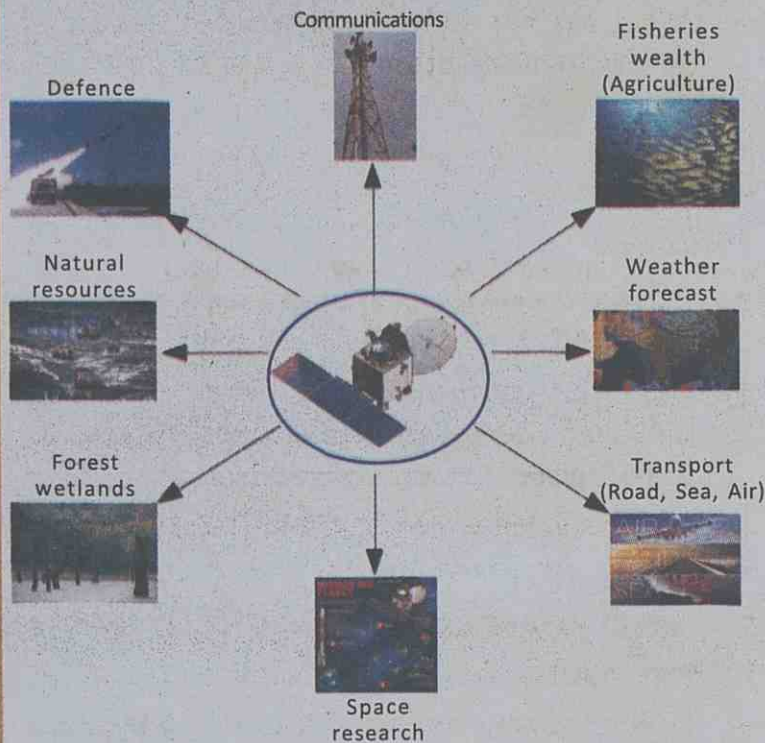

Fig 8.11

For various needs we use different types of artificial satellites. Based on the revolving orbit around the earth they are divided into two:

- Equatorial Satellites
- Polar Satellites

Equatorial Satellites revolve around the earth through an orbit above the Equator.

If the period of revolution of the equatorial satellites is equal to the period of rotation of the earth, they are called Geostationary Satellites.

Those having an orbit at a height of 200 to 1000 km above the North South Poles of the earth are polar satellites.

- Tabulate the uses of geostationary and polar satellites.
- What are the differences between polar and equatorial satellites?

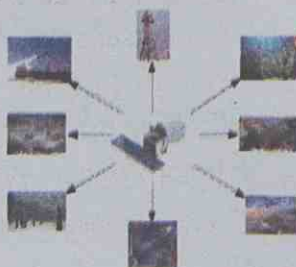

Fig 8.12

Space Exploration

The picture of the universe became more clear with the launching of the space vehicle. The launching of Sputnik I in 1957 by the Soviet Union marked the beginning of space research. Various programmes such as *Luna*, *Appolo*, *Marinar*, *Pioneer*, *Voyager*, *Venera*, *Messenger*, *Cosmos*, *Hubble telescope*, *Kasini*, *Hegans*, *Chandrayan* and *Mangalyan* gave valuable information about planets, satellites, stars and other celestial bodies. International space stations help scientists to conduct many experiments in space.



International space station



Mangalyan

Significant Learning Outcomes

The learner can:

- explain how asterism was formed and how the birth stars got their names.
- explain the formation of Malayalam months and the difference between Malayalam month and zodiac, identify *Njattuvela* and explain the relation between climate of Kerala and *Njattuvela*.
- identify groups of stars through observation
- explain how energy is produced in the sun and stars
- explain the birth and death of stars
- explain the achievements of India in space science

Let us assess

1. We determine asterism based on the stars seen in the background of the moon.
 - a. What is meant by the word 'asterism'?
 - b. In a calendar, 27 December is recorded as *Thiruvathira*. What does it mean?

2. What is a zodiac? How many days does the sun take to pass a zodiac?
3. Which are the areas where artificial satellites are used?



Extended activities

1. With the help of star maps, observe the sky and prepare a note.
2. Prepare a paper on the achievements India has made in the field of space science and present it in the class.
3. Look at the address written by a boy.

..... Name
..... Class, Division
..... Name of School
..... Sub District
..... Education District
..... District

Kerala

India

Asia

The earth

Solar system

Milky Way

The Universe

..... ?

Each of you try to write which part of the universe it would be.
Discuss your position in the whole universe.

4. "My earth, Our earth, I will not take part in any activity to pollute it."

Find more such slogans and popularize them.



Notes

Lined area for taking notes, consisting of multiple horizontal lines within a rectangular border.

Notes

Notes

Notes

Notes

Notes

While using electricity...

Electricity has become an indispensable part of our day-to-day life. Its consumption has increased and hence the hazards due to this have also increased. Of all the electrical hazards reported in India 10 per cent are from our state. Hence there is no need for specific mentioning to ensure the importance of precautionary measures from electricity related hazards.

Safety measures to be adopted:

- Do not operate switches with wet fingers.
- Do not dry hair using a table fan.
- Do not touch the inner part of the adaptor of a TV. Ensure that the adaptor has a cap which is a non-conductor.
- Do not touch on broken electric wires.
- Do not fly kites near electrical lines.
- Do not use metallic pipes or iron hooks carelessly near electric lines.
- Do not lean against electric posts or stay wires. Cattle should not be tied to them. Do not allow plants or creepers grow on them.
- Switch off the main switch in case of fire on electric appliances or on their vicinity.
- Do not pour water over electric lines or appliances to put out fire. Instead, use dry sand or dry powder type fire extinguishers.
- Use only the electric appliances carrying ISI mark.
- Do not use plastic wires for temporary connections to decorations.
- If a person succumbs to electric shock, he/she should be touched only after disconnecting the electrical contact.
- Detach the victim from the electric connection using dry wooden planks or some dry material which is not a conductor.
- Switch off the main switch immediately, in case electric shock is noted.

Electricity saved is equivalent to electricity generated

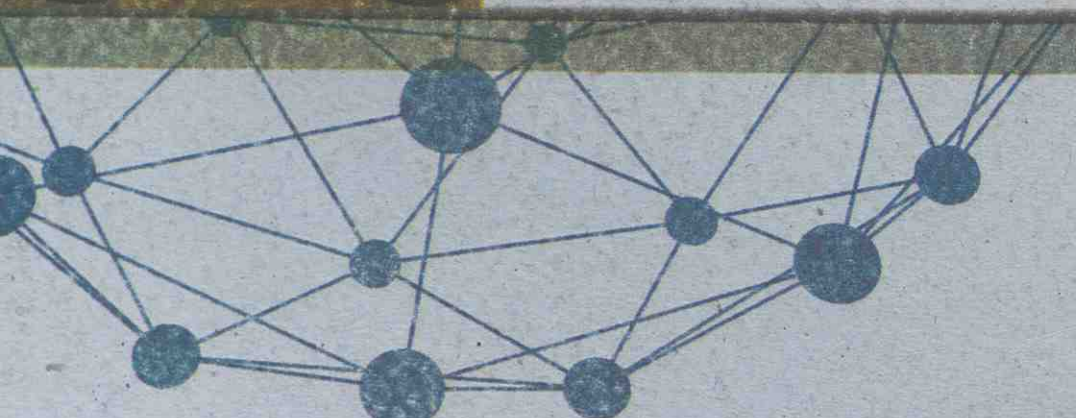
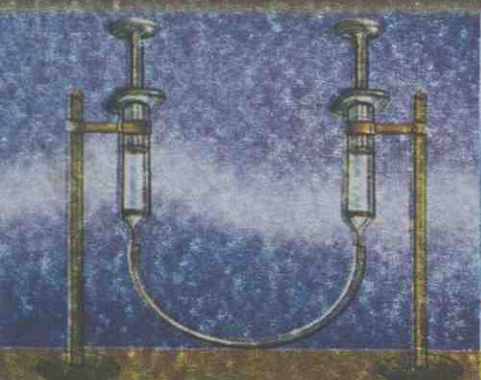

**State Council of Educational
Research and Training (SCERT)**

Vidyabhavan, Poojappura, Thiruvananthapuram
Kerala-695 012. Website www.scert.kerala.gov.in
e-mail scertkerala@gmail.com



Printed by the Chairman & Managing Director
Kerala Books and Publications Society
(An Undertaking of the Government of Kerala)
Kakkanad, Kochi-682 030